

*Stetler*

# **Urban Stormwater Treatment: A Summary of Management Practices**

**DRAFT**

Printed to solicit input, comments and suggestions  
Do not quote

by

Betty T. Rushton, Ph.D.  
Jeremy D. Buchanon

SOUTHWEST FLORIDA WATER MANAGEMENT DISTRICT  
STORMWATER RESEARCH PROGRAM  
2379 Broad Street  
Brooksville, Florida 34604

Betty.Rushton@swfwmd.state.fl.us



### **Acknowledgements**

This project including preparation of this report is being funded , in part, by a Section 319 Nonpoint Source Management Program grant from the U.S. Environmental Protection Agency (US EPA) through a contract with the Stormwater/Nonpoint Source Management Section of the Florida Department of Environmental Protection (FDEP). This is one of four reports submitted for this contract, which was primarily a stormwater monitoring project. This part of the project was designed to investigate methods for treating stormwater that might also be used to improve the performance of stormwater ponds at the Florida Aquarium in Tampa.

### **Disclaimer**

The purpose of this publication is to provide the stormwater management professional community with concise information about current stormwater management practices. Inclusion of manufacturer trade names and product information does not constitute endorsement by the authors or the Southwest Florida Water Management District.

## TABLE OF CONTENTS

INTRODUCTION.....	1
Purpose .....	2
Methods .....	4
STRUCTURAL BEST MANAGEMENT PRACTICES .....	6
DETENTION METHODS .....	7
Wet Detention Pond.....	8
Stormwater Reuse .....	13
Conservation Wet Detention Pond.....	16
Detention Basin (Dry.....	20
Extended Detention Basin .....	24
Wetlands.....	30
Off-Line Treatment System.....	36
INFILTRATION METHODS .....	39
Filtration Systems .....	41
Effluent Filtration.....	44
Retention Pond (Filtration Basin dry) .....	48
Infiltration/Exfiltration Trench .....	51
Subsurface Drainage .....	55
Modular Pavement.....	60
Permeable Pavement .....	64
Geotextiles.....	68
In-Situ Partial Exfiltration Reactor (PER) .....	70
Sand Filters.....	73
Trough-Infiltration-Trench-System .....	78
Packed Bed Filters.....	80
Leaf Compost Treatment System .....	83
LOW IMPACT DEVELOPMENT.....	86
Bioretention.....	87
Impervious Surface Reduction.....	91
On-Lot Treatment .....	94
Roof Storage.....	98
Dry Well .....	101
Vegetated Swale.....	103
Vegetated Filter Strip .....	107
Green Parking and Green Streets .....	111
CHEMICAL TREATMENT .....	114
Alum Treatment .....	115
Powdered Activated Carbon-Alum Coagulation.....	118
Organoclay .....	119
Flocculents.....	121
Sorbents .....	124

END OF PIPE TREATMENT.....	126
Use of Existing Treatment Facilities.....	127
Screening.....	129
Dissolved air Flootation (DAF).....	132
IN POND METHODS.....	135
Periphyton Filtration.....	136
Diversion Structure.....	138
Biofiltration with gravel beds.....	140
Biofiltration Mollusk Species.....	142
UNDERGROUND TREATMENT DEVICES.....	144
BaySaver® Separation System.....	145
Continuous Deflection System (CDS).....	148
Downstream DefenderJ.....	151
Multi-chambered treatment train (MCTT).....	153
Stormceptor®.....	155
Stormfilter™.....	158
StormTreat™.....	160
Filterra.....	162
Vortechs™.....	165
Baffle Boxes.....	167
Vegetation Separating Baffle Box.....	170
CATCH BASIN INSERTS.....	172
Ultra-Urban® Filter.....	173
StreamGuard™ Catch Basin Insert.....	175
Grate Inlet Skimmer Box.....	177
TEMPORARY STORAGE FOR CSO=S.....	179
Flow Balance Method.....	180
Temporary Street Storage.....	182
Vault Storage.....	184
Pipe Storage.....	187
Catch Basin Outflow Reduction.....	189
NONSTRUCTURAL BEST MANAGEMENT PRACTICES.....	191
EDUCATION.....	192
Public Education Programs.....	193
Animal Waste Control.....	196
Erosion and Sediment Control.....	198
GOVERNMENT RESPONSIBILITIES.....	200
Catch Basin Cleaning.....	201
Street sweeping.....	204
Roadside Ditches.....	207
SITE PLANNING.....	210
Riparian Areas.....	211
Soil Rehabilitation.....	215
Trees.....	218

Cisterns..... 221  
REFERENCES ..... 224

*Maintenance*

Routine inspection and repair is all the maintenance necessary. The biological process is self-maintaining and the succession of mollusk on the bedding is a natural process that does not require any intervention (Gondko and Krupanek 2000).

*References*

Gondko, Roman and Janusz Krupanek. Accessed 2000. Biofiltration  
<http://maestro.unep.or.jp/ietc/Publications/TechPublications/TechPub-8b/bio.html/>

Newell, R.I.E., J.C.Cornwell, and M.S.Owens. 2002. Influence of Simulated Bivalve  
[http://www.aslo.org/lo/toc/vol\\_47/issue\\_5/1367.html/](http://www.aslo.org/lo/toc/vol_47/issue_5/1367.html/)

## UNDERGROUND TREATMENT DEVICES

Water quality inlets and oil-water separators are a group of pre-constructed devices that are engineered for stormwater pollutant removal designed for ultra-urban areas (i.e. areas where parking lots, roads, and sidewalk can cover nearly 100 percent of the land). These devices are ideal for small urban drainage basins, which have a high percentage of impervious surface and limited space. Applications may include new urban stormwater systems or retrofitting old systems. (Wade *et al.* 1997) Water quality inlets are typically constructed of precast concrete, or fiberglass, and partitioned into multiple compartments. Manufacturers have created many different configurations of water quality inlets, but the primary focus of designs is to remove grit, oil/grease, and nutrients through a treatment series. For the purpose of this report, water quality inlets/ oil-water separators are included with traditional structural BMPs, but each manufactured device will be addressed separately.

A variety of companies make these units. The manufacturers included here are a sampling and other devices may be as effective or even more effective. A technology review of manufactured stormwater treatment technologies is available on the internet (Brueske 2000). The United States Environmental Protection Agency has a web site where over 34 devices can be accessed with information from the technology providers (EPA 2004). [http://www.epa.gov/NE/assistance/ceit iti/tech cos/stor.html/](http://www.epa.gov/NE/assistance/ceit%20iti/tech%20cos/stor.html/)

### BaySaver® Separation System by BaySaver, Inc

The BaySaver® system is a physical separator designed to maximize stormwater treatment based on flow. The system consists of two equally sized, cylindrical treatment chambers (primary and secondary), and a flow separator. The treatment chambers are pre-constructed of concrete and have vented manhole covers for maintenance access.

The primary chamber is positioned in-line with the storm sewer pipe and separator device. The secondary chamber is positioned diagonally from the primary chamber. It connects with the separator device by inflow and outflow pipes at a 90° angle. The separator is constructed of black HDPE components including a weir, inflow and outflow pipes, and corrugated pipe for the housing.

Under low flow conditions, inflowing runoff receives initial settling in the primary chamber. Large particles settle out quickly, leaving suspended particles and floatables to be diverted to the secondary chamber for quiescent settling. Diverted water enters the secondary chamber through a submerged inlet. As the water level rises, clean supernatant water moves out of the chamber, into the separator unit, and discharges. Moderate flows receive only initial treatment in the primary chamber before discharging. During periods of high flow, no treatment occurs. Water is allowed to bypass the system to prevent flooding of the drainage basin.

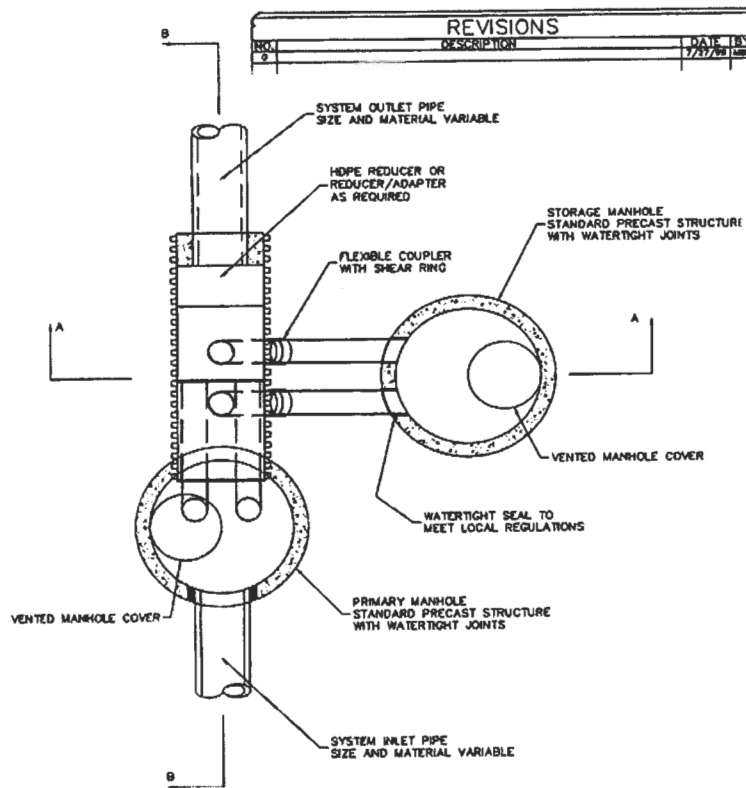

Figure: Plan view of a Baysaver Separation System (Source: BaySaver®, Inc., 1999).

*Pollutant Removal Efficiency*

REMOVAL EFFICIENCY RANGE (%)

TSS	TP	TN	Pb	Cu	Zn	COD
*57 - 97	No Data	No Data	No Data	No Data	No Data	No Data

\*Calculated from loads

*Advantages*

- \$ May be used where available land is limited.
- \$ Useful in retrofit applications.
- \$ Unit is installed below grade.
- \$ Manholes allow clean-out and visual inspection.
- \$ No re-suspension of stored sediments.
- \$ Units may be used in various configurations and as pretreatment devices.
- \$ Maintenance does not require manned entry under normal conditions.
- \$ Does not require green space and meets AASHTO H-20 standards for load bearing.
- \$ Easy to install in standard pre-cast manholes.

*Disadvantages*

- \$ Increasing the storage volume of treatment chambers does not significantly affect the removal efficiency.
- \$ Greater maintenance frequency as compared with traditional BMPs.
- \$ Larger storms by-pass the system.
- \$ Frequent inspections and maintenance are needed.
- \$ No aerobic biological reduction of pollutants.
- \$ Other treatment will be necessary to treat dissolved constituents
- \$ Best used as a pre-treatment device to remove solids

*Cost*

Material costs, and maintenance costs vary significantly throughout the country. For information on BaySaver® costs in your area, contact BaySaver®, Inc. or an authorized representative directly.

Separator Unit Size	Maximum Impervious Area Treated	Estimated Material Cost
1K	1.2 acres	\$6,740*
3K	3.6 acres	\$10,840*
5K	5.5 acres	\$13,940*

\*Cost depends on type of outfall pipe

### *Maintenance*

All water, debris, oils, and sediment from the storage manhole is removed using a vactor truck. A high- pressure hose, is used to clean the storage manhole. The two structures should be refilled with clean water. These procedures are intended to remove all the collected pollutants from the system while minimizing the volume of water that must be disposed of. Additional local regulations may apply,. A contractor licensed by the local authority should be responsible for the cleanout.

### *References*

BaySaver®, Inc., 1999.

BaySaver®, Inc. Accessed 2004. <http://www.baysaver.com/>

Brueske, C.C. 2000. Technology Review:  
<http://depts.washington.edu/cwws/Research/Reports/ultraurbn.pdf/>

### Continuous Deflection System (CDS) by CDS Technologies, Inc

A CDS unit is a gross pollutant separator that removes floatable and non-floatable litter, sediment, and debris from stormwater runoff. It consists of an inlet, a cylindrical treatment chamber surrounded by a screen, a bypass weir, and an outlet. The device traps gross pollutants within the center of the unit by the vortical motion of inflowing water. Water is filtered through a metal screen, which has elongated perforations measuring 3.8 mm in diameter and is angled away from the direction of the vortical movement. The screen is designed to allow treated water to exit the separation chamber while deflecting debris towards the center of the chamber. The moving water inside the separation chamber also prevents the screen from becoming blocked, causing the unit to fail. Ultimately, trapped solids drop out of the separation chamber by vortex force or when water saturation occurs. Solids accumulate in a sump located below the separation chamber. The interior of the sump is lined by a basket, which holds the accumulated solids during clean-out efforts. The basket is lifted vertically out of the top of the unit using a boom truck. There is no need for manual cleaning under normal operation. CDS units are available in six designed capacities, depending on the amount of normal inflow received. Smaller units are usually factory pre-constructed then installed. Larger units are framed and poured onsite. As previously mentioned, the device has a bypass weir located at the inlet of the separation chamber to allow for bypass during high flows.

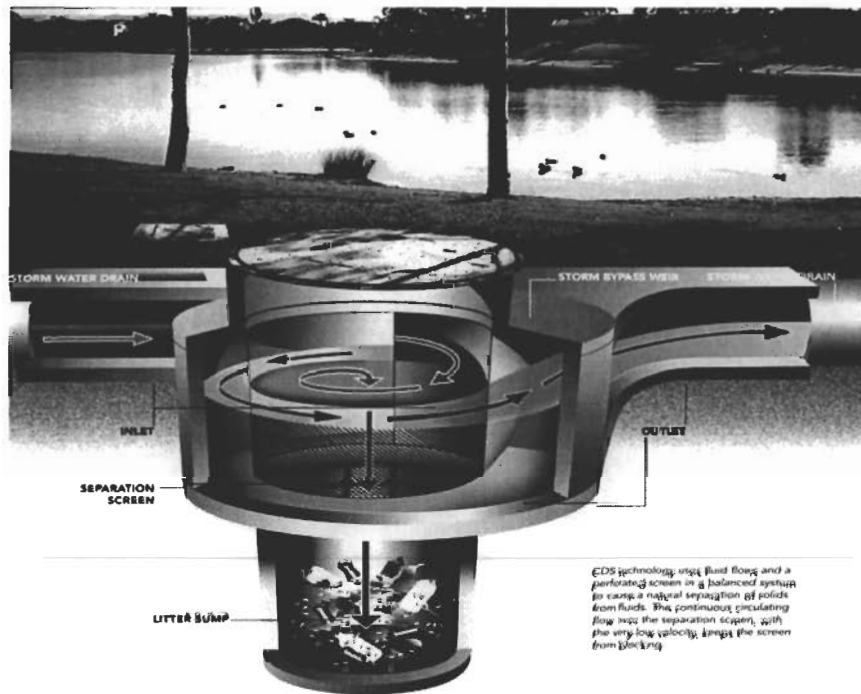

Figure: Diagram of CDS unit. (Source: CDS Technologies, 1998)

*Pollutant Removal Efficiency*

REMOVAL EFFICIENCY RANGE (%)

SOURCE	TSS	TP	TN	Pb	Cu	Zn	COD
Strynchuk	62 - 78	21 - 49	13	No Data	No Data	No Data	40 - 74
Rushton 2004*	68 - 71	15 - 18	2 - 3	No Data	-14 TO 6	-1 TO 6	No Data
Walker 1999	65 - 70	21 - 30	Variable	No Data	No Data	No Data	No Data

\* Includes the gross solids collected in the unit as well as the load WQ data to evaluate efficiency

*Advantages*

- \$ Minimum amount of space required
- \$ Unit is installed below grade
- \$ Highly efficient in removing litter and large sediment particles
- \$ Filter screen is resistant against blockage
- \$ Large manhole allows for optimal visual inspection and maintenance access
- \$ May be used in retrofit applications
- \$ Best used for pretreatment

*Disadvantages*

- \$ Greater maintenance frequency as compared with traditional BMPs.
- \$ Large storms by-pass system.
- \$ Organic garden litter collected exports soluble nutrients downstream.
- \$ Most effective at high flows, but then subject to bypass
- \$ Not suitable for estuarine systems that grow barnacles and clog screens or other systems where screens can get clogged.
- \$ Removal efficiency declines with decreasing particle size (Allison et al. 1998).
- \$ Has a tendency to clog

*Cost*

New Construction: \$12,800 - \$630,000 installed  
 Retrofit: \$13,600 - \$630,000 installed  
 (CDS Technologies 2000)

*References*

Allison, R. T. Walker, F. Chiew, I.O'Neill, and T. McMahon. 1998. Gross Pollutant Removal  
 Brueske, C.C. 2000. Technology Review:

<http://depts.washington.edu/cwws/Research/Reports/ultraurban.pdf>

CDS Technologies, Inc., 1998.

CDS Technologies, Inc., 2000. Personal communication with Julie Case.

Herr, Jeffrey L.; Harper, Harvey H., 1999. Removal of Gross Pollutants From Stormwater Runoff Using Liquid/Solid Separation Structures <http://www.stormwater-resources.com/library.htm>

Rushton, B.T. and R. James. Submitted 2004. Quantifying Pollutant Removal by Hydrodynamic Separators. In BMP Book. American Society of Civil Engineers.

Rushton, B. T. 2004. Broadway Outfall Stormwater Retrofit Project

Strynchuk, Justin 1999. Evaluation of Storm Sample #5. <http://www.stormwater-resources.com/library.htm>

Strynchuk, Justin; Royal, John; England, Gordon, 1999. The Use of CDS for Sediment Control <http://www.stormwater-resources.com/library.htm>

Walker, T.A.; Allison, R.A.; Wong, T.H.F.; Wootton, R.M., 1999. Removal of Suspended Solids

U.S. Environmental Protection Agency. Accessed 2004. Fact Sheet: Hydrodynamic Separators. EPA 832-F-99-017 <http://www.epa.gov/OW-OWM.html/mtb/hydro.pdf>

## Downstream Defender<sup>™</sup> by H.I.L. Technology, Inc

The Downstream Defender<sup>™</sup> is a separation device that is designed to remove stormwater pollutants by creating an internal vortex of inflowing water. It is also designed to capture settleable solids, and floatables, such as oil and grease. There are four standard size units, 4, 6, 8, and 10 feet in diameter. Each standard size Downstream Defender<sup>™</sup> is designed to remove 90% of all particles with a specific gravity of 2.65 down to 150 microns. The system consists of a concrete cylindrical vessel with a sloping base and internal components. Raw stormwater is introduced tangentially into the side of the cylinder and spirals down the perimeter. At a 30 degree angle, heavier particles settle out by gravity and the drag forces on the wall and base of the vessel. As the flow rotates about the vertical axis, solids are directed towards the base of the vessel where they are stored in the collection facility. The internal components direct the main flow away from the perimeter and back up the middle of the vessel as a narrower spiraling column rotating at a slower velocity than the outer downward flow.

A dip plate is suspended from the underside of a component support frame. This dip plate serves two purposes: 1) It locates the shear zone, the interface between the outer downward circulation and the inner upward circulation where a marked difference in velocity encourages solids separation and 2) It establishes a zone between it and the outer wall for floatables, oil and grease capture.

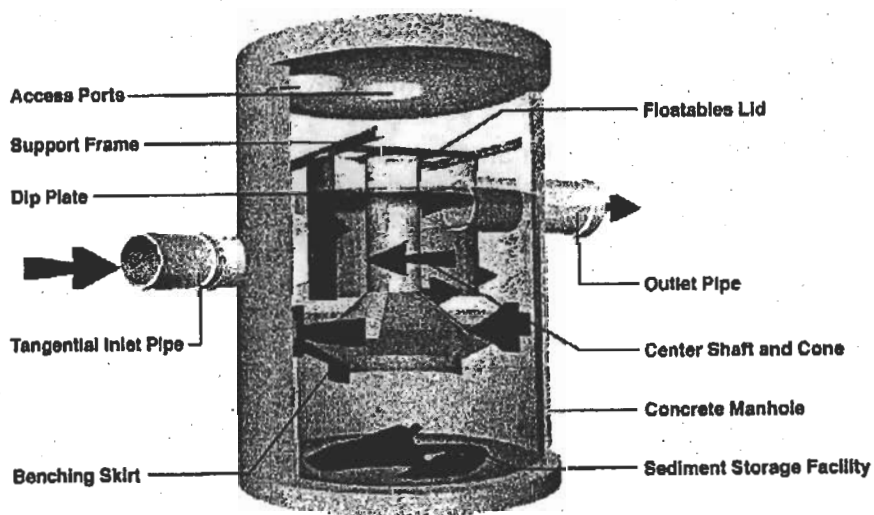

Figure: Diagrammatic Cutaway of the Downstream Defender<sup>™</sup>. (Source: HIL Technologies, Inc. 1999).

### *Pollutant Removal Efficiency*

Typical results for total suspended solids show overall removal efficiencies in excess of 90% of particles greater than 150 microns.

REMOVAL EFFICIENCY RANGE (%)

TSS	TP	TN	Pb	Cu	Zn	COD
90	No data	No data	No data	No data	No data	No data

*Advantages*

- \$ Retains floatables, oils and grease.
- \$ Removes solids, grit, sand, and silts.
- \$ Units have no moving parts.
- \$ Requires no external power source.
- \$ Designed to operate over a wide range of flows.
- \$ Has small footprint, therefore used for retrofits.
- \$ More versatile than conventional stormwater treatment systems.
- \$ Low headloss across the Downstream Defender
- \$ Used in conjunction with the Reg-U-Flo Vortex Valve to maximize storage in the collection system, it provides an effective control of quantity and improves the quality of stormwater discharges.

*Disadvantages*

- \$ Requires regular maintenance and removal of trash.
- \$ Large storms by-pass system.
- \$ Needs another form of treatment for smaller particles.
- \$ Organic debris stored in unit may release inorganic nitrogen and phosphorus.

*Cost*

Approximate delivered costs for the Downstream Defender® range from \$10,000 to \$35,000.

*Maintenance*

By the time the flow reaches the top of the vessel, it is virtually free of solids and is discharged through the outlet pipe. A simple sump vac procedure is used to periodically remove the floatables and solids from the collection facility. With regular maintenance, The Downstream Defender® will treat stormwater for a period in excess of 30 years.

*References*

H.I.L. Technology, Inc. 1999. Downstream Defender® Manufacturer Information, H.I.L. Technology, Inc., Portland, Maine. <http://www.hil-tech.com/dwnstrm.html/>

U.S. Environmental Protection Agency (US EPA). Accessed 2004. Fact Sheet: Hydrodynamic Separators. EPA 832-F-99-017. <http://www.epa.gov/OW-OWM.html/mtb/hydro.pdf/>

### Multi-chambered treatment train (MCTT)

The MCTT is a stormwater treatment device that combines filtration, settling, and ion exchange as the mechanisms of pollutant removal. The device consists of three chambers, each providing a phase of treatment. Stormwater runoff enters the MCTT through a catch basin, which funnels water into the grit chamber. In this primary phase, a suspended filter of packing balls removes larger particles (sand; litter; etc.). The filter also aerates the water, removing volatile constituents. Finer particles that pass through the filter are removed by settling in the base of the chamber.

The second phase of treatment occurs in the main settling chamber. Suspended and dissolved constituents are removed by adsorption and extended settling time in a permanent pool. To improve settling, a matrix of angled tubes are located in the base of the chamber. Sediments collected on the tubes, eventually slide down to the chamber floor. Oil-absorbing pillows float on the surface of the supernatant, skimming off floating oil. Water exits the main chamber through a 0.9 cm orifice leading into the final phase.

The third chamber produces the final treatment by filtration. Water trickles through a mixed filter media of sand, peat, activated carbon, and textile. Fine particles, metals, and other remaining constituents are removed by adsorption to media and ion exchange.

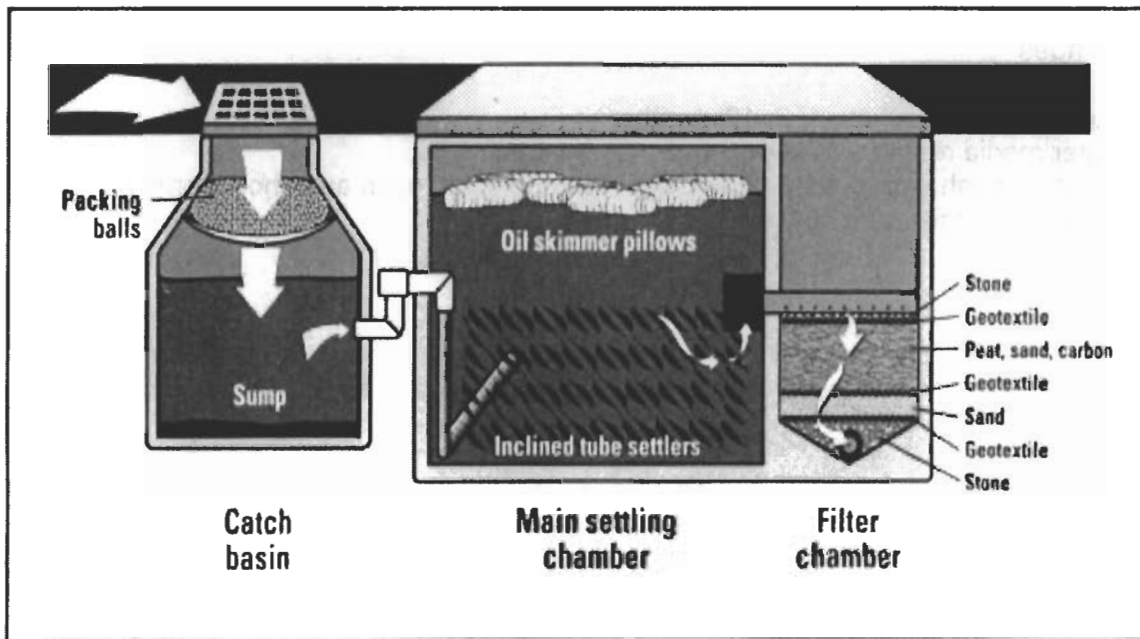

Figure: Cross section of a MCTT unit (Source: Corsi et al. 1999)

*Pollutant Removal Efficiency*

REMOVAL EFFICIENCY RANGE (%)

Report	TSS	TP	TN	Pb	Cu	Zn	COD
Corsi et al. 1999	*98 - 99	*84 - 93	No Data	*95 - 97	*89 - 92	*89 - 93	*83 - 94
EPA 1999	**25 - 100	NR	No Data	**29 - 100	**159 - 100	**3 - 97	**40 - 100

\*Calculated from loads

\*\*Calculated from concentrations

**Advantages**

- \$ Minimum amount of space required.
- \$ Unit is installed below grade.
- \$ May be used in retrofit applications.
- \$ Targets source areas of pollutants.

**Disadvantages**

- \$ Requires cleanout every 6 -12 months.
- \$ Filter media requires changing every 3 - 5 years.
- \$ Organic trash stored under water where inorganic nitrogen and phosphorus may be released to the water column.

**Cost**

No reported cost reference in the literature. It is more expensive than stormwater ponds (excluding land cost) and is most suitable for small and isolated paved critical source areas, from about 0.25 to 2.5 acres.

**Maintenance**

Must be periodically examined (about every 6 months), with major maintenance activities every several years.

**References**

Corsi, Steven R.; Greb, Steven R.; Bannerman, Roger T.; Pitt, Robert E., 1999.

Pitt, Robert; Robertson, Brian; Barron, Patricia; Ayyoubi, Ali; Clark, Shirley, 1999.

### Stormceptor® by CSR Hydro Conduit

that efficiently removes sediment and oil from stormwater run-off, and stores these pollutants for safe and easy removal. Stormceptor protects the watershed from hazardous material spills and every-day runoff pollution. It is unique in that its patented internal by-pass prevents the resuspension and scouring of trapped pollutants during high flow storm events.

A fiberglass insert separates the upper (by-pass) and lower (separation/holding) chambers. In areas where oil or chemical spills accumulate in substantial volume between cleaning, the fiberglass insert provides dual wall containment of floating oils and chemicals inside the treatment chamber. This makes Stormceptor ideal for industrial properties, gas stations, parking lots and sites where there is a potential for oil or chemical spills.

There are three variations of the Stormceptor unit that apply the same treatment approach for different applications. All three units are constructed of precast concrete with fiberglass inserts. Stormwater runoff flows into the unit, sediments settle to the bottom while oil, grease, and other floatables rise and are trapped beneath the fiberglass insert. There is an In-Line Stormceptor for linear applications, an Inlet Stormceptor for small drainage areas, and a Submerged Stormceptor for partially submerged pipes.

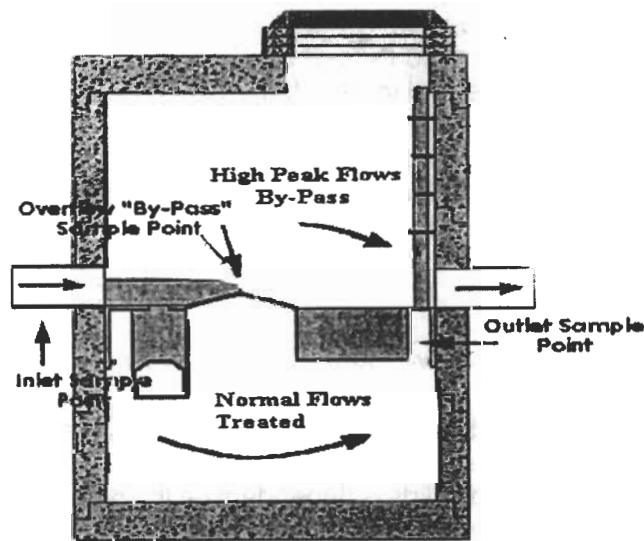

Figure: Schematic of Stormceptor® Unit with Sampling Locations (Source: Richard A. Claytor 1999).

*Pollutant Removal Efficiency*

Stormceptor® is more efficient in small storms than large storms.

REMOVAL EFFICIENCY RANGE (%)

Report	TSS	TP	TN	Pb	Cu	Zn	COD
Manufacturer	40-80	Na	Na	Na	Na	Na	Na
Greb, et al., 1998	21	17	Na	24	Na	17	Na
Labatiuk, 1997	52	NA	Na	51	22	39	Na
Como Park, MN, 1998	80	36	Na	Na	Na	Na	Na

*Advantages*

- \$ Unique design that prevents re-emulsion of collected petroleum products, since it removes and retains materials that are trapped.
- \$ Leaves minimal temperature impact to treated runoff.
- \$ Economical in time and space costs at the construction sites. There are significant capital and annual cost savings as compared to other water quality devices.
- \$ The design procedure is simple and standardized. The design simplification has made design approval faster and easier.
- \$ Uniquely and optimally designed to treat the first flush and a very large percentage of the Total Annual Runoff Volume and to treat the greatest percentage of the total pollutant load from impervious surfaces.
- \$ Flexible and can replace an existing manhole structure.
- \$ Can be used in floodplains and tidal areas without losing collected contaminants.
- \$ Easy to install and easy to maintain.

*Disadvantages*

- \$ Has a moderate ability to remove particulate pollutants (e.g., solids, PAH and metals), but virtually no ability to remove soluble pollutants (with the exception of dissolved phosphorus). This is not surprising since the device relies on particulate settling for pollutant removal.
- \$ Submerged Stormceptor is not effective for oil removal under fully submerged conditions.
- \$ Ability to remove suspended solids is dependent on the depth of rainfall in each storm event. When rainfall increases, the removal rates drop.
- \$ Needs additional treatment for removal of dissolved constituents.

*Cost*

No reported cost reference in the literature, but cost data are available from the vendor.

### *Maintenance*

The Stormceptor, like all water quality practices, will require periodic maintenance. Typical water quality inlet maintenance is recommended to be done four or more times a year, but the Stormceptor requires only once a year maintenance due to its unique design. Maintenance is simple, safe, quick, and does not require physical entry into the unit. Maintenance is generally done using conventional vactor truck equipment.

### *References*

Brueske, C.C. 2000. Technology Review:

<http://depts.washington.edu/cwws/Research/Reports/ultraurban.pdf>

C.S.R. Hydro Conduit, Inc. N/D. Stormceptor® System Stormwater Quality

Greb, S., S. Corsi, and R. Waschbusch. 1998. Evaluation of Stormceptor7

Labatiuk, C., V. Nataly, and V. Bhardwaj. 1997. Field Evaluation

Richard A. Claytor. 1999. Performance of a Proprietary Stormwater Treatment Device

Stormceptor Coporation. No date. Stormceptor System Stormwater Quality Treatment

Vincent H. Berg, P.E., Senior Environmental Engineer. No date Stormceptor®

U.S. Environmental Protection Agency. Accessed 2004. Fact Sheet: Hydrodynamic Separators.. EPA 832-F-99-017. <http://www.epa.gov/OW-OWM.html/mtb/hydro.pdf>

## Stormfilter™ by Stormwater Management

The Stormfilter™ improves the quality of stormwater runoff before it enters receiving waterways by removing non-point source pollutants, including sediments (TSS), oil and grease, soluble metals, nutrients and organics. It is a passive, flow-through stormwater filtration system consisting of a concrete vault that houses rechargeable cartridges, which trap particulates and absorb pollutants such as dissolved metals, nutrients, and hydrocarbons. The Stormfilter is offered in four different configurations: cast-in-place, precast, linear, and catch basin. The precast, linear, and catch basin are customized for larger flows and may be either uncovered or covered underground units. The cast-in-place units are customized for larger flows and may be either uncovered or covered underground units. There is a high flow bypass, StormGate, available for those sites where high flow occurs. The Stormfilter uses a variety of filter media to target and remove pollutants from stormwater runoff. These filter media remove sediments, soluble phosphorus, nitrates, soluble metals, and oil and grease. In many cases, a combination of media is recommended to maximize the effectiveness of pollutant removal. These filter media include perlite, CSF7 leaf media, zeolite,

### GENERAL SPECIFICATIONS

- StormFilter capacity – 15 gpm/cartridge (up to 4 cartridges)
- Peak hydraulic capacity – 1.0 CFS
- Hydraulic drop (Rim to Invert) – 26.75"
- Outlet pipe diameter – up to 8"
- Load-bearing capacity – 14,000 lbs (H-20 optional)

(For higher flows or heavier loads, contact the application engineers at Stormwater Management)

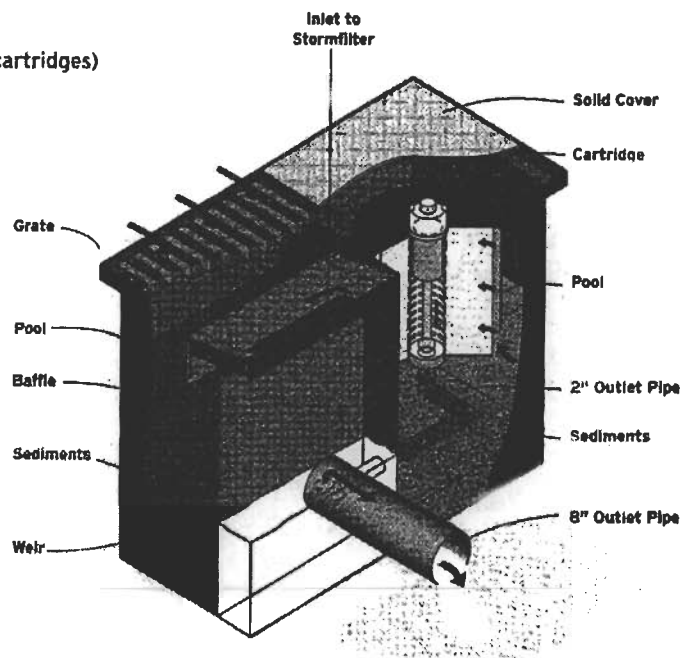

and pleated fabric inserts.

Figure: Diagram for catch basin Stormfilter™ (Source: Stormwater Management, Inc., 2000).

### Pollutant Removal Efficiency

According to the vendor, it removes up to 90% of all solids, 85% of oils and greases and 91% of solubilized heavy metals.

### *Advantages*

- \$ Offers a variety of media to remove site-specific pollutants.
- \$ Adaptable to fit individual characteristics- is suitable for streets and highways; transit facilities; residential, retail and commercial development; business and industrial sites; and maintenance facilities.
- \$ Rechargeable cartridges to remove pollutants of concern such as soluble phosphorus, nitrates, metals, sediments and oils and greases.
- \$ Uniquely effective for constrained sites and treatment of high stormwater flows.
- \$ Uses less than 10% of land compared to ponds and swales.
- \$ High treatment capability - can treat flows from 0.13 to 8.0 cfs and greater.
- \$ Saves up to 10 times the cost of traditional stormwater treatment methods.

### *Disadvantages*

- \$ Complex installation - must be accomplished by a trained professional.
- \$ Large storms by-pass unit.
- \$ Requires frequent inspections and maintenance

### *Cost*

No reported cost reference in literature, but complete cost data are available from the vendor.

### *Maintenance*

Stormfilter maintenance is straightforward, efficient, and cost-effective. Filter cartridges are removed, the vault cleaned and inspected, and new, recharged cartridges installed. Maintenance is typically annual, but can depend on the pollutant load characteristics of each site.

### *References*

Brueske, C.C. 2000. Technology Review:

<http://depts.washington.edu/cwws/Research/Reports/ultraurban.pdf>

Stormwater Management, Inc. 2000. [www.stormwatermgt.com/products/stormfilter.shtml](http://www.stormwatermgt.com/products/stormfilter.shtml)

U.S. Environmental Protection Agency. Accessed 2004. Fact Sheet: Hydrodynamic Separators.. EPA 832-F-99-017. <http://www.epa.gov/OW-OWM.html/mtb/hydro.pdf>

### StormTreat™ by StormTreat® Systems

The StormTreat™ is a self-contained stormwater treatment system that combines filtration, sedimentation, infiltration, and nutrient uptake by wetland plants in one unit. The unit is constructed of a recycled-polyethylene tank measuring 9.5 feet in diameter and is installed flush with grade. Water enters the unit and is filtered through a grit-filter, which removes large particles. Water then enters a settling chamber where finer particles are removed and treated water is transferred to a series of three final settling chambers. After the settling phase, the partially treated water moves into the outer chamber containing wetland plants and gravel for final treatment. The outflow then is released into the soil surrounding the outside of the unit. Each unit size is standard and the number of units needed is determined by considering the area of impervious surface treated, storm design, and if detention storage is utilized prior to the unit (StormTreat™ 1995).

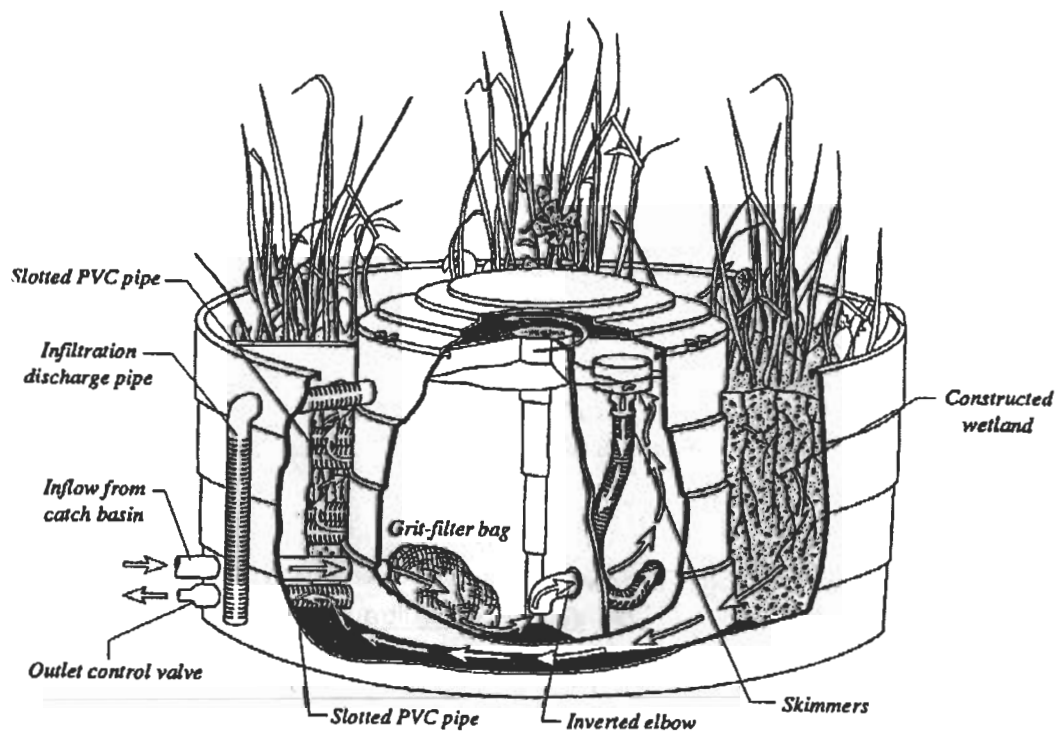

Figure: Product fact sheet for STORMTREAT™ system, Inc

*Pollutant Removal Efficiency*

REMOVAL EFFICIENCY RANGE(%)

TSS	TP	TN	Pb	Cu	Zn	COD
99	90	77	77	No Data	90	82

(StormTreat™ 1995, EPA 1999)

*Advantages*

- \$ Minimum amount of space required. And useful for retrofits.
- \$ Unit provides nutrient removal by plant uptake.
- \$ Plants make unit more aesthetically pleasing.
- \$ Requires no energy inputs and may be constructed with recycled materials.

*Disadvantages*

- \$ Multiple units increase costs.
- \$ Grit-Filter bag must be replaced.
- \$ Requires pre-treatment

*Cost*

Approximately \$5,750 - \$6,300 per unit\*

\$6,000 to \$12,000 per treated impervious acre.

\*based on unit price of \$4,900, installation cost of \$500 - \$1000, cost of wetland plants, gravel, and PVC pipe approximately \$350 - \$400

*Maintenance*

Annual inspection (and replacement of grit filter).

Sediment pumping once every three to five years using standard septic system pumper.

*References*

Horsley, S. W. Accessed 2002. Article 96. The StormTreat System.

<http://www.stormwatercenter.net/>

Schmitt, T. et al. 1999. Summary of 3 BMPs. <http://www.swfwmd.state.fl.us/ppr/files/6th.pdf>

StormTreat™ Systems, 1995. StormTreat™ Systems, Inc. <http://www.stormtreat.com/>

U.S. Environmental Protection Agency, 1999. Fact Sheet - Modular Treatment Systems.

<http://www.epa.gov/>

Winkler, Eric. 1997. Technology Assessment Report: StormTreat System™.

## Filterra®

The Filterra® bioretention BMP has been designed to optimize the use of physical, chemical and biological processes to remove stormwater pollution. The system consists of a concrete container which includes a 2-3 inch mulch layer, 1.1 to 3.5 feet of a unique high flow rate treatment media, an observation/cleanout pipe, an under-drain system and an appropriate type plant i.e. flowers, grasses, shrub or tree (Coffman and Siviter 2004).

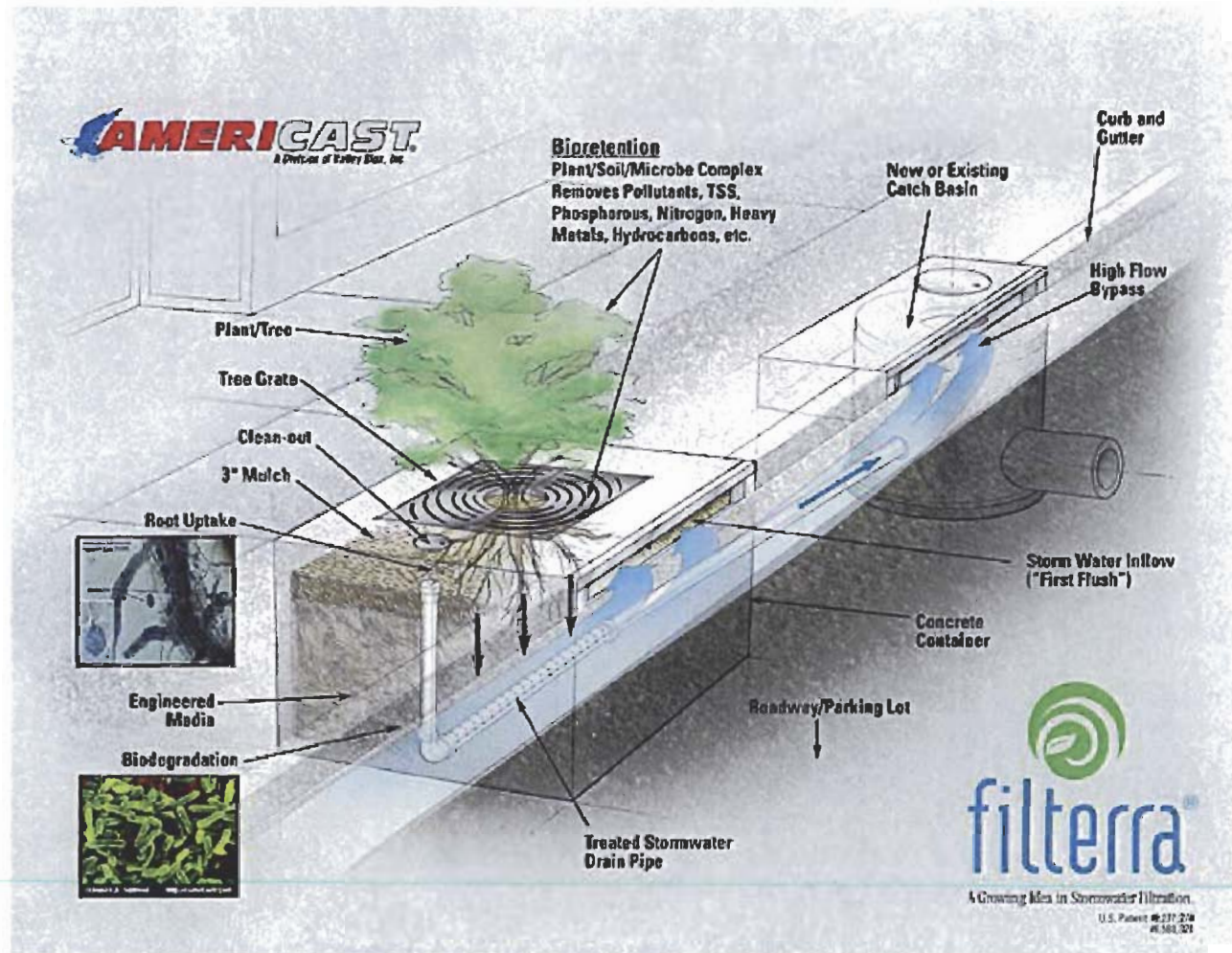

Figure: Schematic of Filterra system installed along a curb. (Source: Americast 2005).

### Pollutant Removal Efficiency

Pollutant removal is a function of the filter surface area to drainage area. As the filter surface area increases relative to the drainage area the pollutant removal will increase up to the maximum pollutant removal capabilities.

REMOVAL EFFICIENCY (%)

TSS	TP	TN	Metals	% filtered
86	74	69	86	91

Source: Coffman and Siviter 2004.

*Advantages*

- Takes up little space (surface area or depth).
- Can be modified to fit any curb line as a drop inlet along roadways.
- It can be installed within the green space or streetscapes of redevelopment projects.
- No pre-treatment is necessary
- If maintained, it has a long life (20 yrs) without a replacement filter.

*Disadvantages*

- An adjacent drainage conveyance system is necessary to connect to the under drain system.
- Overflows must be diverted to a safe conveyance device
- Not suitable for large drainage basins.
- Cannot be used to treat construction runoff.
- Placement of the system must be on a firm base to prevent the device from settling.

*Cost*

Available from the vendor

*Maintenance*

The manufacturer provides for the inspection, care and maintenance for the first two years. After this initial period, the operator should follow the manufacturers guidelines. In general, annual routine inspections and maintenance activities are similar to any landscaped area and would include removal of trash, debris and sediment, replenishment of the mulch, and care or replacement of plants. During extreme droughts the plants may need to be watered.

*References*

Americast. Accessed 2005. Filterra® Stormwater Bioretention filtration System.

<http://www.americastusa.com/filterra.html/>

Coffman, L.S. and t. Siviter. 2004. Filterra® by Americast: Advanced Bioretention System: Discussion of the pollutant Removal Mechanisms and design Strategies.

Low Impact Development Center. Accessed 2005. Construction of tree Box Filters.  
[http://www.lid-stormwater.net/treebox/treeboxfilter\\_construct.htm/](http://www.lid-stormwater.net/treebox/treeboxfilter_construct.htm/)

Virginia Stormwater Management Program. Accessed 2005. Technical bulletin 6.  
<http://www.dcr.state.va.us/sw/stormwat.htm/>

**Vortechs™** by Vortechtechnics, Inc

The Vortechs stormwater treatment system is a linear configuration installed underground. It utilizes a swirling motion created by a tangential inlet that directs sediments and settleable solids toward the center of a grit chamber. A center barrier traps floatables in the oil chamber. A flow control chamber discourages re-suspension of pollutants and wash-out. As the inflow rate increases, the swirling rate increases, which increases sediment removal rates and forces material, which may have been deposited at the end of the inlet pipe during low flows into the center of the chamber.

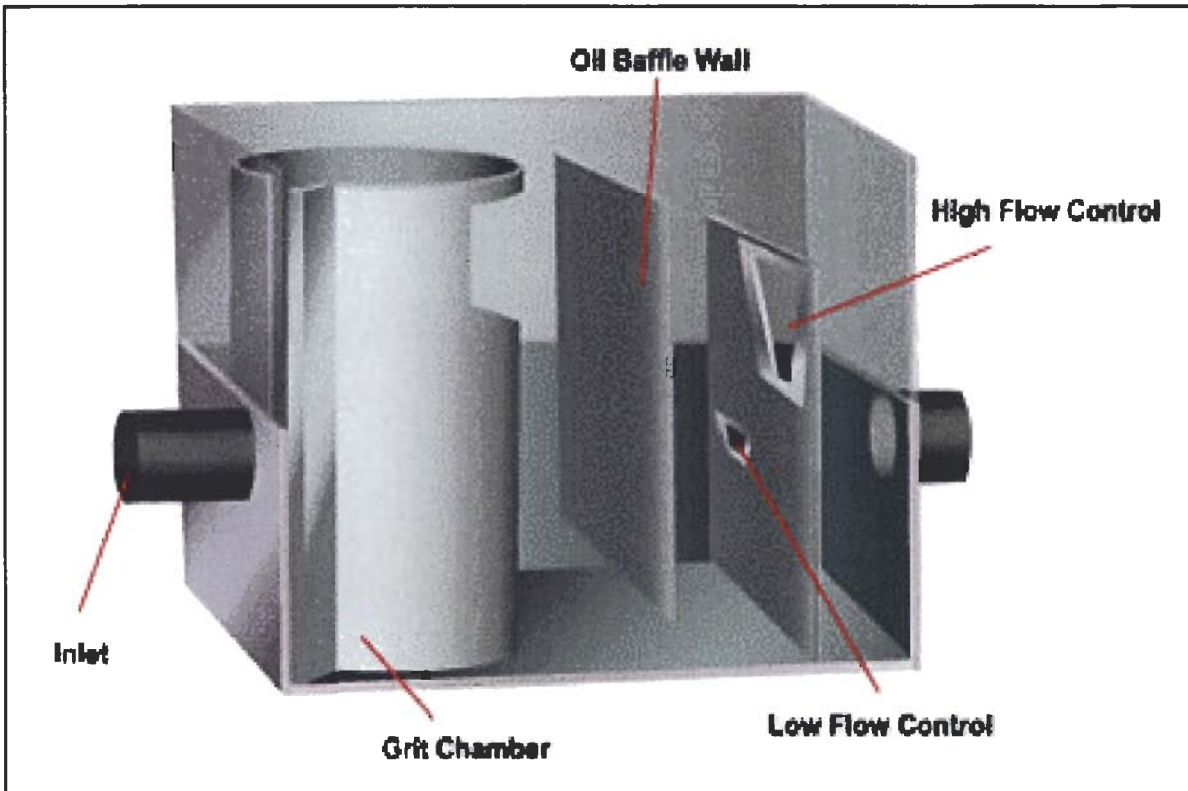

Figure: Schematic of **Vortechs™** unit (Source: Vortechtechnics, Inc., Pamphlet).

*Pollutant Removal Efficiency*

REMOVAL EFFICIENCY RANGE (%)

TSS	TP	TN	Pb	Cu	Zn	COD
80	40	40	N/A	N/A	N/A	N/A

*Advantages*

- \$ Resistant to flow surges, re-suspension, and washout.
- \$ Can be designed to match a predetermined peak storm level.
- \$ Linear and is stored underground, the system saves land area.

*Disadvantages*

- \$ Primarily for oil and grease.
- \$ Grit chambers are prone to clogging.
- \$ Requires frequent maintenance.

*Cost*

No reported cost reference in literature, but cost data are available from the vendor.

*Maintenance*

Clean-out can be accomplished by a vacuum truck and inspection is done on a quarterly basis.

*References*

Vortechnics, Inc. no date. [www.vortechnics.com](http://www.vortechnics.com)

## Baffle Boxes

Baffle boxes are a traditional non-proprietary treatment system used for many years to remove sediments from stormwater runoff. They are in-line concrete or fiberglass boxes with two to three chambers for sediment to settle into. The primary function of baffle boxes is to remove sediment, suspended particles, and associated pollutants from storm water. Baffle boxes are located either in-line or at the end of storm pipes. Baffle box pollution removal is based on the concept of slowing the flow velocity through the box, thereby allowing solids and associated pollutants to settle to the bottom of the box. As water encounters the baffles, flow velocity decreases, allowing particles with a settling velocity greater than the horizontal flow velocity to settle to the bottom of the box (EPA 2001).

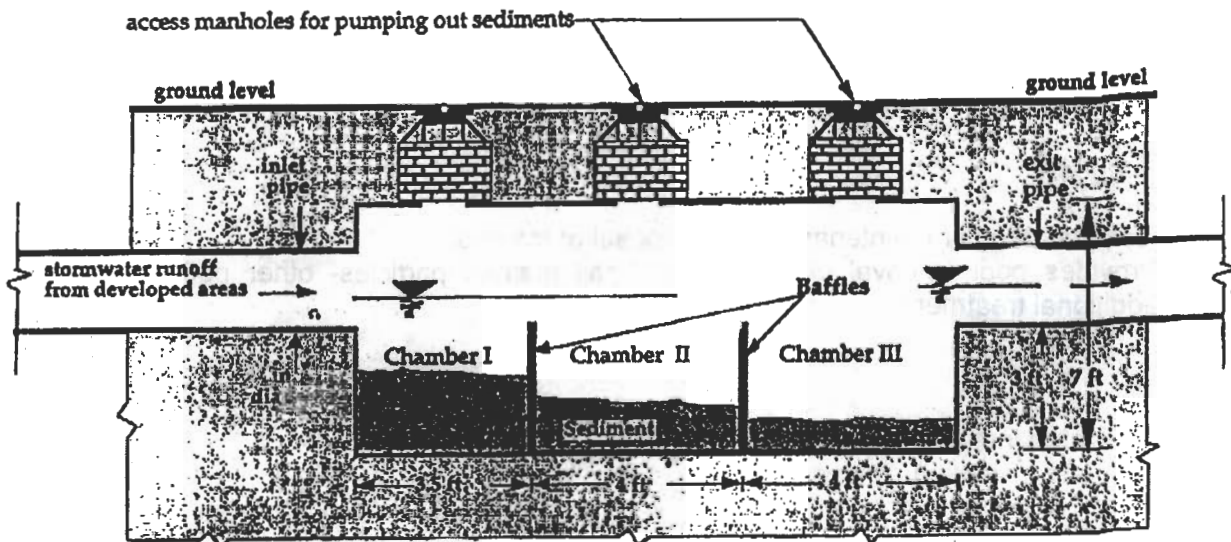

Typical Baffle Box Design.

Figure: Source: Herr and Harper, no date

### *Pollutant Removal Efficiency*

Provide 90% removal efficiencies for coarse sediment and 28% removal efficiencies for fine sediment. Yearly clean out records show the box was cleaned three times and 2,558 kg (5,639 lbs) of sediment was removed on a yearly basis. Mineart & Singh (1994) measured constituents in the sediments trapped in the storm drain inlets. They found the following median amounts (mg/kg) of copper, lead, zinc and petroleum hydrocarbons respectively: Residential = 38, 44, 215, 5000; commercial = 57, 111, 598, 2050; and industrial = 47, 117, 307, 1950.

REMOVAL EFFICIENCY RANGE (%)

TSS	TP	BOD	TN	Cu	Zn	COD
71*	38	-25 to 39	No data	No data	No data	No data
80**	30	No data	0	No data	No data	No data

\*England no date

\*\* England 2001

Advantages

- \$ Can be designed to treat any flow.
- \$ No new land is required for the construction of a baffle box.
- \$ Can be constructed in existing pipe easements or in street right-of-ways.
- \$ Effective for removing coarse sediments, trash, and debris.
- \$ Reduces flow velocities.

Disadvantages

- \$ Requires regular maintenance and disposal of material.
- \$ Provides poor removal efficiency for small grained particles- other pollutants require additional treatment.

Cost

- \$ Estimated installed cost: \$50,000- \$80,000.
- \$ Estimated installed cost per cfs treated: \$2,800-\$1,600.
- \$ Average cost of installing a baffle box was around \$22,000 in Florida (England 1997)

Maintenance

- \$ Cleaned out with vacuum trucks and soil is taken to a landfill.
- \$ More frequent clean outs increase removal rates and reduce the amount of sediment flushed downstream (Mineart and Singh 1994).
- \$ Average clean-out cost is \$450 (by private contractor) (England 1997)

References

Environmental Protection Agency (EPA 832-F-01-004) 2001 [http://www.epa.gov/OW-OWM.html/mtb/baffle\\_boxes.pdf/](http://www.epa.gov/OW-OWM.html/mtb/baffle_boxes.pdf/)

England, Gordon 1997. Accessed 2000. Stormwater Retrofitting Techniques <http://www.stormwater-resources.com/library.htm>

England, Gordon 1999. Baffle Boxes and Inlet Devices for Stormwater BMP's.  
<http://www.stormwater-resources.com/library.htm>

England, Gordon, P.E. and John Royal. (no date). Using Baffle Boxes for Treatment  
<http://www.stormwater-resources.com/library.htm>

England, Gordon, P.E. and John Royal. 2001. Two Baffle Boxes in Series  
<http://www.stormwater-resources.com/library.htm>

Pandit, Ashok 1996. Physical Modeling of a Stormwater Sediment Removal Box. .  
<http://www.stormwater-resources.com/library.htm>

Jeffrey L. Herr, P.E. and Harvey H. Harper, Ph.D., P.E. no date. Removal of Gross Pollutants  
From Stormwater Runoff

Mineart, Phillip and Sujatha Singh. 1994. Value of More Frequent Cleanouts.  
[www.cwp.org](http://www.cwp.org)

Royal, J.C. and R.D. Vanderbleek. 1994. Stormwater Monitoring Program, Accessed 2002.  
<http://www.stormwater-resources.com/library.htm>

**Vegetation Separating Baffle Box – Suntree Technologies, Inc.**

This baffle box design captures sediment, nutrient rich vegetation, and litter without head loss, and can more than handle the maximum flow of the drainpipe. The baffled chambers measure 36 inches deep and are spaced to create three equally sized chambers. The tops of the baffles are below the incoming and outflow openings in the ends of the box. The screens elevate the foliage and other debris four inches above the baffles. Screens hang from the ceiling to collect floating trash. These screens swivel up during high flows to minimize flow blockage and upstream flooding. This separates the foliage from the water, capturing foliage and preventing nutrient loss to the water flow. Each of the screens is hinged and can easily swing out of the way to give a vector truck access to the lower chambers. In order to prevent water flowing into the baffle box during cleaning, a damper is built into each end of the baffle box. The access lids in the top of the box slide down an aluminum track built into the ends of the baffle box to make a damper. This will stop the water flow from either or both ends, allowing faster, more effective cleaning.

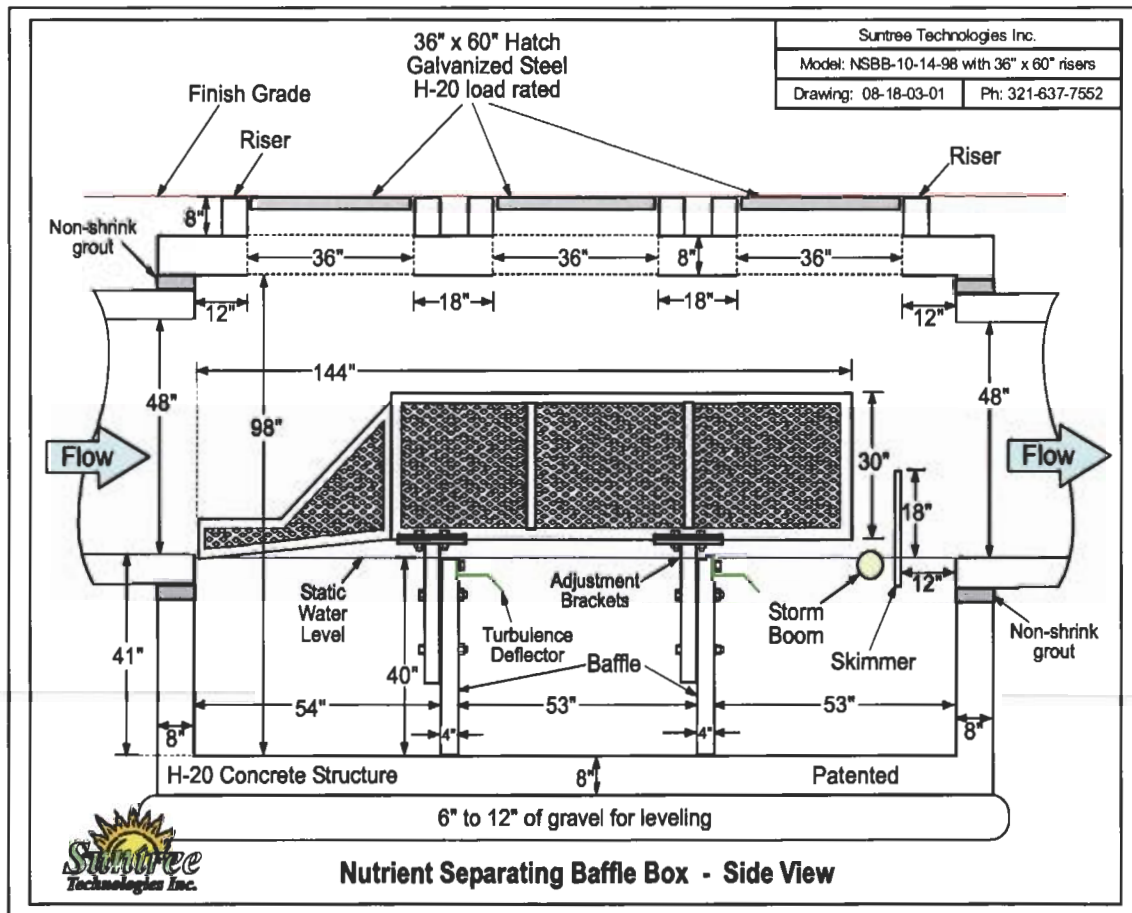

Figure: Advanced baffle box with nutrient/vegetation/litter separation (Source: Suntree Technologies, Inc.)

*Pollutant Removal Efficiency*

The amount of rainfall and pipe velocities influence pollution removal efficiency with greater efficiency reported for larger rain events (England and Royal 2002). The reductions reported in the table are for the larger rain events and represent water concentrations measured at the inflow and outflow of grab samples. Over 35,000 pounds of sediment was removed during an eight-year period.

REMOVAL EFFICIENCY RANGE (%)

TSS	TP	TN	Pb	Cu	Zn	BOD
71	38	No data	No data	No data	No data	39

*Advantages*

- The lightweight design allows the box to be transported to the job site on an ordinary yard trailer.
- Requires no additional land acquisition and can be installed in easements in line with existing pipes
- Easy access through the top and a rounded bottom allow fast and easy cleaning with a vector truck
- Prevents bacterial and odor build up by holding organic matter above the standing water.
- Head loss is minimal and comparable to a large square catchbasin.

*Disadvantages*

- Requires frequent inspections and clean outs.
- Requires the water table to be sufficiently deep.

*Cost*

Cost depends on the size of the unit. Prices range from \$650 for a 24" by 36" unit to \$1,275 for a 36" by 60" unit. Current prices for all units including larger units are available from the vendor.

*Maintenance*

Similar to maintenance required for traditional baffle box.

*References*

England, Gordon and John Royal. Accessed 2002. <http://www.stormwater-resources.com/library.htm>

Suntree Technologies, Inc. <http://www.suntreetech.com/>

### **CATCH BASIN INSERTS**

An effective and relatively inexpensive method for removing litter, oil, grease, and large sediment is the installation of catch basin inserts in the inlets of storm sewer catch basins. These devices are designed to intercept litter and large sediment particles before they enter the storm sewer system. Devices are composed of a perforated frame (metal or plastic structure) and an interior filter. Water enters by flowing directly into the top of the device from curb gutters or parking lot sheet-flow. Litter and sediment are immediately retained while fine particles and hydrocarbons are captured as the water passes through the filter material. As a result of removing oil, grease, and other gross pollutants, test results have shown a moderate reduction in metals associated with urban stormwater runoff.

### Ultra-Urban® Filter by AbTech Industries

AbTech Industries has designed the Ultra-Urban® Filter in two models: Model CO1414 for curb inlets and model DI2020 for drop inlets (AbTech Industries 2001) The CO1414 is a modular unit requiring the installation of multiple units along the length of the curb inlet. Model DI2020 is a singular unit that is suspended below the grate of vertical drop inlets. A plastic collar is installed around the opening of the drop inlet, which serves as a funnel. The units are composed of a plastic exterior housing with an internal debris basket. The space between the internal debris basket and external housing is filled with an absorbent material called Oars<sup>7</sup> Smart Sponge™. The material absorbs and retains petroleum hydrocarbons without leaching and without absorbing water.

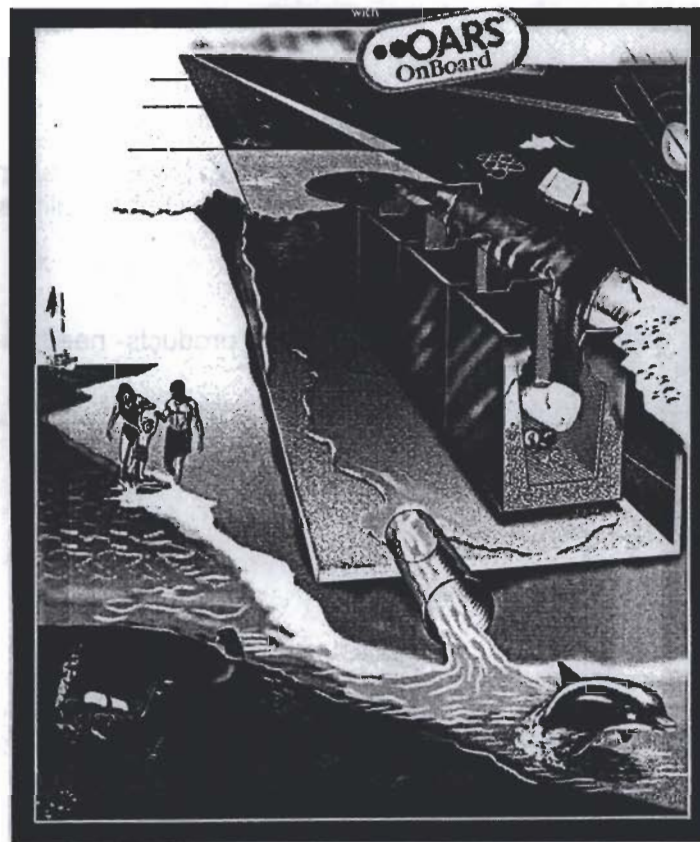

Figure: Idealized drawing of an AbTech™ Ultra Urban Filter (Source: Abtech Industries, Informational Pamphlet)

*Pollutant Removal Efficiency*

REMOVAL EFFICIENCY RANGE (%)

TSS	TP	TN	Pb	Cu	Zn	COD
30-90	97	96	No data	No data	No data	No data

*Advantages*

- \$ Maintenance is achieved by vector trucks.
- \$ Easy installation.
- \$ Non-obtrusive - no structural changes to existing stormwater system
- \$ Oars can be recycled by Ogden Waste Treatment Systems facilities.

*Disadvantages*

- \$ Primarily filters sediments, trash, and petroleum products- needs additional treatment for other pollutants.
- \$ Requires regular maintenance and disposal of material.

*Cost*

\$600-\$900

*Maintenance*

Cleaning with a vector truck for grated inlets and one man with a barrel and a truck for curbed inlets. One man can clean Twenty to thirty inlets per day. The hydrocarbon absorbents in the Ultra-Urban Filters are replaced when saturated with oil. Maintenance should be done 2-3 times a year.

*References*

Abtech Industries. No date. Environmental Solution from AbTech.  
<http://www.abtechindustries.com/>

American Society of Civil Engineers. 2001. Guide For Best Management Practice (BMP)

**StreamGuard™ Catch Basin Insert** by Foss Environmental Services

Containing approximately 3 pounds of hydrocarbon-absorbing polymer, the Passive Skimmer is designed to float in the sump of ordinary catch basins, oil/water separators, or storm water vaults. This innovative polymer absorbent is contained in a screen pillow, which allows for long-term exposure to oil-contaminated water unlike fabric-covered products, which rapidly become coated with oil and sediment preventing further absorption in stormwater applications.

Figure:. Diagram of the Streamguard (Source: [www.ges-inc.com/StreamguardInsert.html](http://www.ges-inc.com/StreamguardInsert.html))

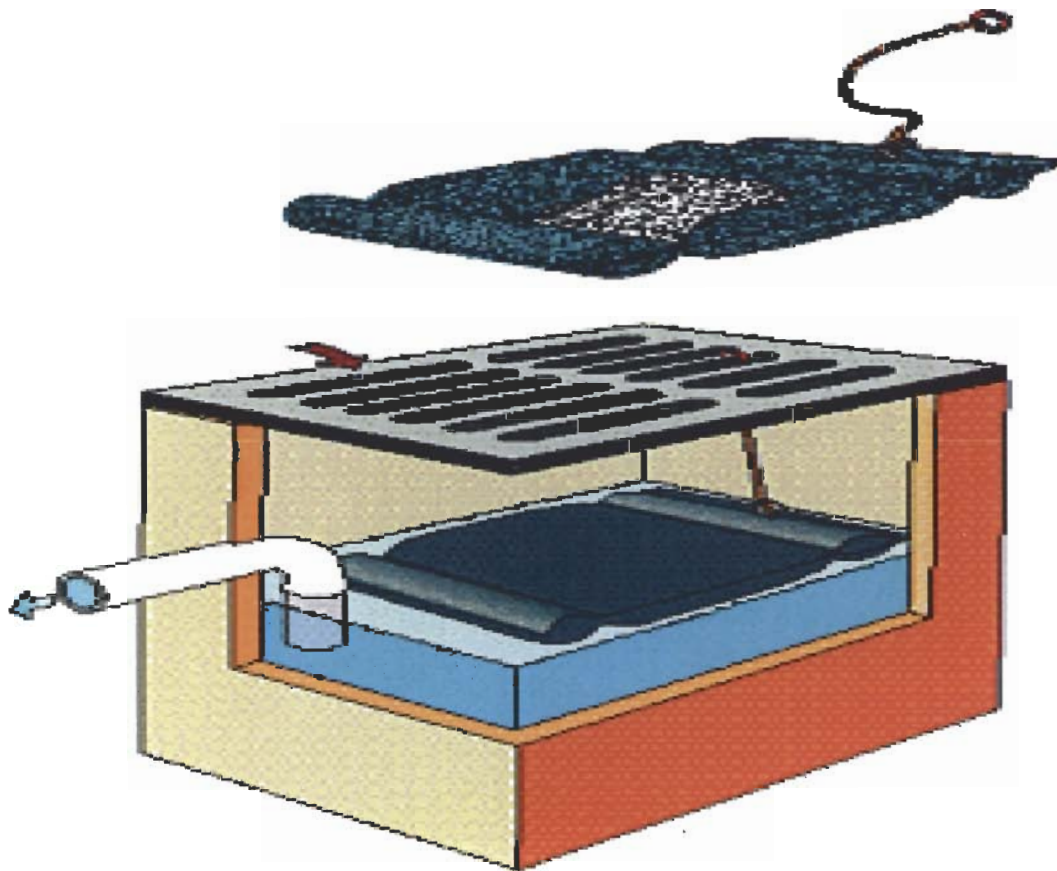

*Pollutant Removal Efficiency*

The Passive Skimmer is particularly effective in capturing hydrocarbons which otherwise accumulate at the surface of sumps then discharge suddenly during the peak flow of a rain storm event. A 93% reduction of oil and grease and an 80% reduction in sediment was measured in stormwater runoff.

REMOVAL EFFICIENCY RANGE (%)

TSS	TP	TN	Pb	Cu	Zn	COD
80	No data	No data	No data	No data	No data	No data

*Advantages*

- § Will not deteriorate or release absorbed hydrocarbons.
- § Will not impede the flow of water through the stormwater collection system.

*Disadvantages*

- § Prone to clogging by sediments (Macpherson, no date)

*Cost*

\$93.00 for Insert for Oil and Grease only.  
\$820.00 for 1 to 4 units.

*References*

Global Environmental Services, Inc. [www.ges-inc.com/StreamguardInsert.html](http://www.ges-inc.com/StreamguardInsert.html)

Macpherson, John, no date <http://www.fossenry.com/portfacility/bmps.htm>

### Grate Inlet Skimmer Box – Suntree Technologies, Inc.

The grate inlet skimmer box is made of durable fiberglass, with stainless steel filter screens backed by heavy-duty aluminum grating. As stormwater enters the inlet through the grate it comes in contact with and passes through a storm boom designed to intercept and absorb hydrocarbons. The unit drains dry after every storm so that the debris that is collected in the unit is stored in a dry state, which helps to contain the nutrient pollutant load, prevents the filter from going septic, and prevents mosquitoes from breeding in the unit. The units are custom made for each individual drop box to insure that runoff does not flow in around the edge of the installation and miss the box.

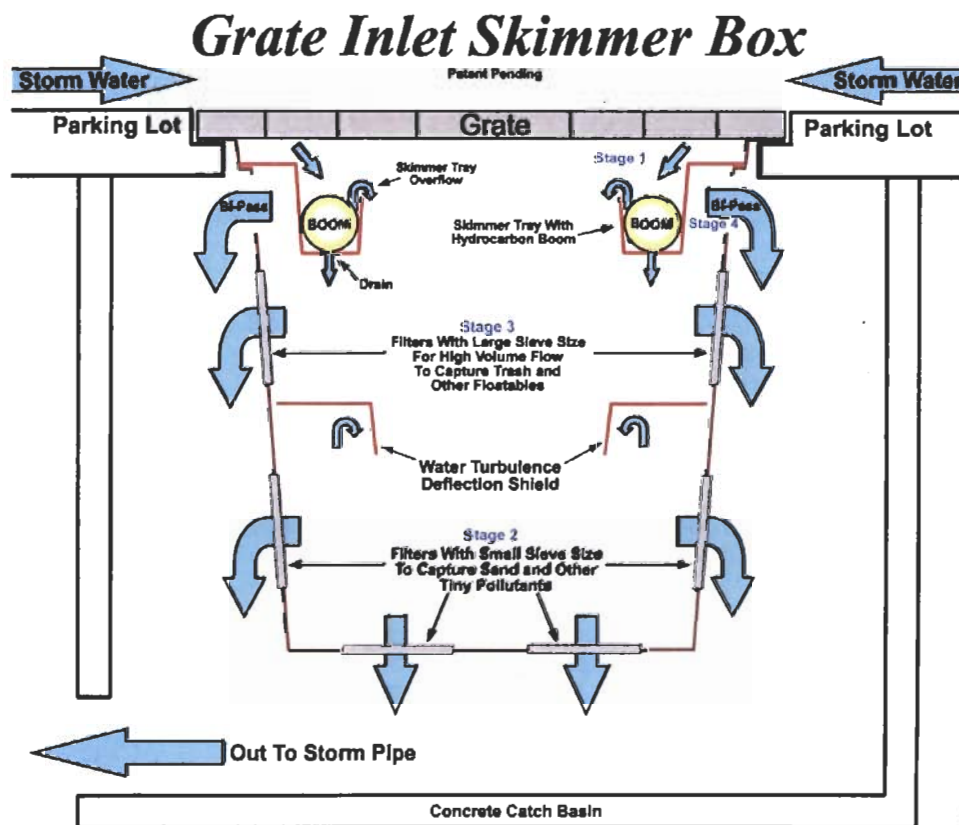

Figure: Schematic of a Grate Inlet Skimmer Box (Source: Suntree Technologies, Inc)

#### Pollutant Removal Efficiency

Grab samples were taken from standing water in the bottom of the seven drop boxes before the skimmer box inserts were installed (n=11) and after they were installed (n=14) to estimate removal efficiencies. The samples were usually taken within two days after a rain event. This is not a rigorous evaluation but indicates reduction in pollution resulted from the installation of the skimmer box inserts. The only removal that was definitively quantified was the material retained in the skimmer box inserts, which shows 15-cubic feet per year of potentially polluting gross solids from this

5.67-acre drainage basin was intercepted before it could be flushed into the pond (Rushton et al. 2004).

REMOVAL EFFICIENCY RANGE(%)

TSS	TP	TN	Pb	Cu	Zn	COD
94	56	50	77	54	49	No data

*Advantages*

- Multi-stage filtration process captures a wide variety of pollutants, from hydrocarbons, grains of sand, grass clippings, to paper cups.
- The water turbulence deflection shield keeps the majority of the water turbulence adjacent to the small sieve size filters preventing the escape of tiny particles through the upper filter.
- Dries out after each storm event.
- Suitable for retrofit situations in urban areas and as part of a treatment train.

*Disadvantages*

- Has to be cleaned out and maintained to work properly.
- Has a tendency to clog and hold water.

*Cost*

The cost depends on the size of the drop box, but seven units installed in Tampa cost less than \$8,000 and treated a 5.67-acre drainage basin (Rushton et al. 2004).

*References*

Rushton, B. T., D. Huneycutt, and K. Teague. 2004. Characterization of Three Ponds

Suntree Technologies, Inc. <http://www.suntreetech.com>